

Version 1.02
March 22, 2018

User manual
DMX
DimGate DIN
DGD-1-D4DIM4AC

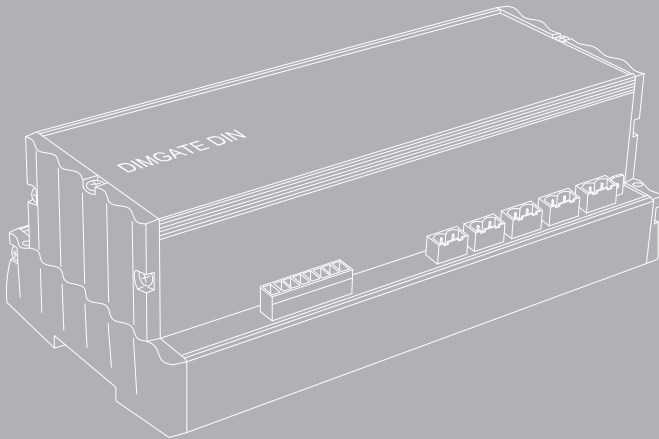
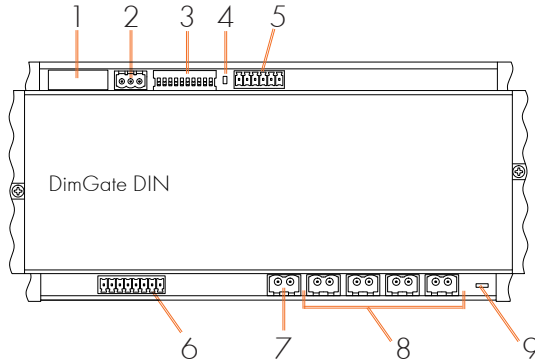

Table of contents

| | |
|---|-----------------------|
| 1 | Appearance |
| 1 | Specifications |
| 2 | Safe operation |
| 2 | General information |
| 3 | Installation |
| 3 | RDM |
| 4 | Operation |
| 4 | Technical maintenance |
| 4 | Transport and storage |
| 5 | Connection scheme |

Appearance



Pic.1 Location of device interfaces and indicators

| | | | | | |
|---|---------------------------|---|--------------------------|---|------------------------|
| 1 | Fuse | 4 | DMX/Status LED indicator | 7 | Neutral wire connector |
| 2 | Power input | 5 | DMX512 connector | 8 | AC dimming channels |
| 3 | Address/ Mode-switcher | 6 | Outputs 1-10V/0-10V | 9 | Ground terminal |

Specifications

| | |
|-------------------------------|---------------------------------|
| Control interface | DMX512, RDM |
| Number of DMX addresses | 8 |
| Controllable output lines | 4 AC and 4 analogue 1-10V/0-10V |
| Connectors | Terminal blocks 2EDGVC, 15EDGVC |
| Input Voltage | AC 90-230 V, 50 Hz |
| Max current per channel 230 V | 10 A |
| Maximum load power | 2.4 kW per channel |
| Mains Fuse | 0.5 A |
| Setup | DIP switchers, RDM |
| Operating Temperature | -40...+70°C |
| IP Rating | IP 20 |
| Dimensions, mm | 210(D) x 105(H) x 75(W) |

Safe operation



WARNING!

The device uses hazardous voltage AC 230 V

To ensure safe and reliable operation of the devices, please observe the following requirements:

- Use the device only for its intended purpose;
- Do not use devices that show signs of malfunctioning;
- Avoid strong physical impacts on the device;
- Protect devices and cables from contact with moisture or other corrosive liquids;

Whenever a fault is detected in the device, please contact the manufacturer.

General information

DimGate DIN is hybrid DIN-rail dimmer that converts DMX512 data to 4 independent 110-230 VAC outputs up to 2.4 kW each to provide dimming of incandescent lamps and other dimmable luminaires. Additional four 1-10V (or 0-10V) outputs are supplied to integrate devices with 1-10V dimmable drivers and electronic ballasts into DMX controlled surrounding.

Key features:

- Dim AC lines and 1-10V/0-10V lines from one device
- Independent phase inputs for dimmable 230V channels
- Active analogue 1-10V/0-10V outputs, capable to connect up to 100 drivers/ballasts
- Maximum surge protection – power supply optimized for voltage from 100 to 315 V
- AC switcher mode
- Full galvanic isolation of all ports (except 1-10V)

Installation

Before mounting and power up, it is necessary to verify protective earthing and cable connections.

1. Ensure the device has no damage caused by transportation.
2. Install the device on DIN-rail.
3. Connect power supply according to connection scheme.
4. Connect DMX512, AC dimming lines, 1-10 outputs according to connection scheme.
5. Connect the grounding circuit to the grounding clamp terminal.
6. Set DMX start address on DIP switcher section 1-9. DMX start address is set as binary code where section 1 refers to LSB and section 9- to MSB, ON position- to binary «1», OFF position- to binary «0». Valid address range from 1 to 504.
7. Select the necessary AC channels mode by DIP switcher section 10. Set section 10 to OFF to select AC dimmer function. Set section 10 to ON to select AC switcher function.
8. Apply a MAINS voltage to the terminal «~230V».

RDM

Device supports DMX address assignment and dimmer/switcher function changing via RDM.

To select RDM address assignment mode, set all DIP-switcher sections to OFF. In other cases the actual DMX address will be indicated in RDM parameters anyway.

AC dimmer and AC switcher functions can be selected via RDM by choosing corresponding "device personality".

Operation

DimGate DIN devices start their normal operation in a few seconds after they have been powered up.

Output channels operate according to values receiving from DMX512 port. AC channel 1 corresponds to DMX start address set by DIP switcher, AC channel 3- to start address+3. 1-10V channel 1 corresponds to start address+4, 1-10V channel 4- to start address+7. When AC dimmer mode selected, actual level on AC outputs changes proportionally to DMX value. When AC switcher mode selected, AC channels just switch the load ON and OFF, DMX value 0-127 switches the load OFF, DMX value 128-255 switches the load ON.

LED indicator shows the status of input DMX512 signal. If indicator is red, no DMX512 signal detected on input. If indicator is green, valid DMX512 signal is received. The indicator blinks on change DMX values controlling device's outputs.

Technical maintenance

Maintenance the device, search and troubleshooting should be performed by service personnel. The device should be free from dirt, dents, connecting cables and wires must be intact and securely fastened.

Transport and storage

The device, packaged in containers should be stored in warehouses under conditions:

- temperatures from -50°C to $+80^{\circ}\text{C}$;
- relative humidity 95% ;
- the vapor acids, alkalis and other aggressive substances is not allowed.

Connection scheme

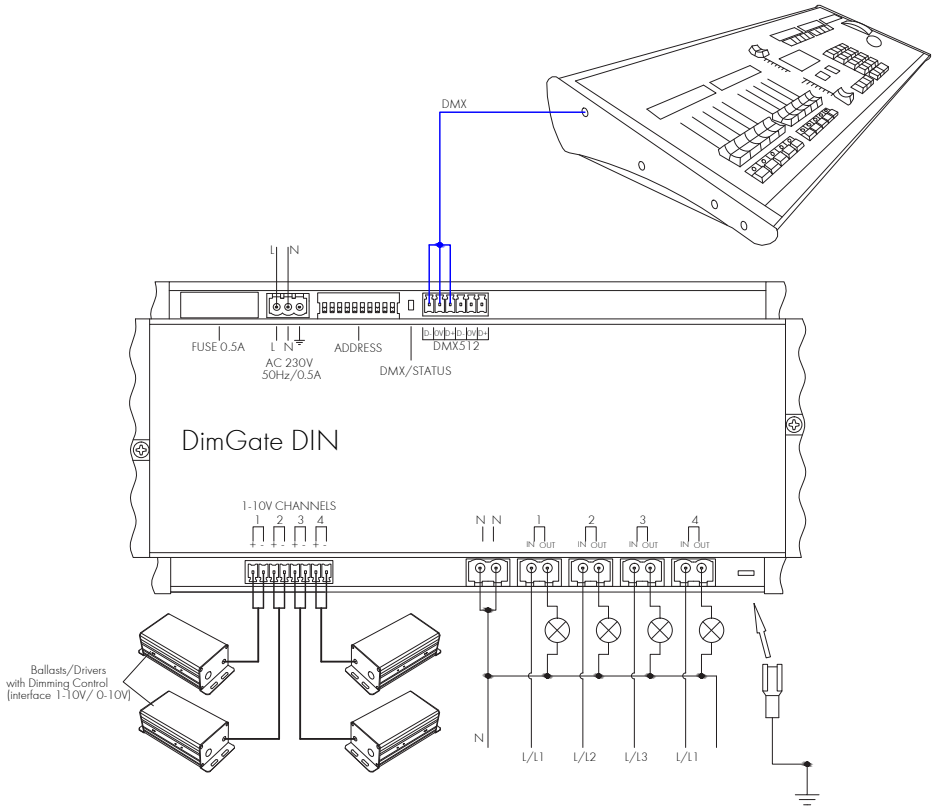

Please send all your warranty-related questions to
support@sundrax.com
All Sundrax products are covered by a 36 months warranty.



Sundrax Electronics,
6008, First Central 200
2 Lakeside Drive, Park Royal, London
NW10 7FQ United Kingdom
+ 44 (0) 208 991 33 19
office@sundrax.com
www.sundrax.com